

**FRONTGRADE**  
Gaisler

**Our way to the Solar System**

1957

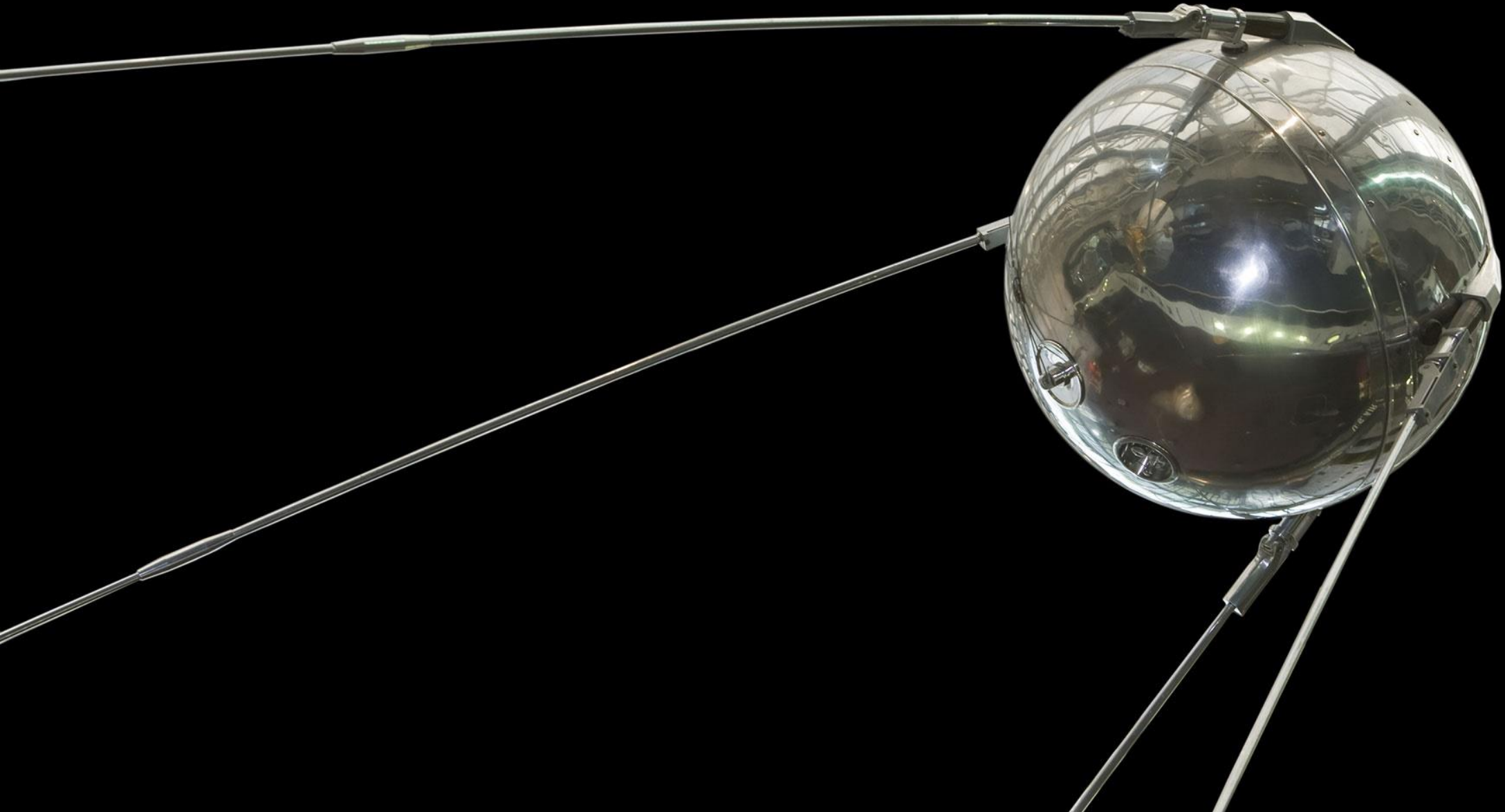

1968



# 2001: a space odyssey



HAL 9000

1969

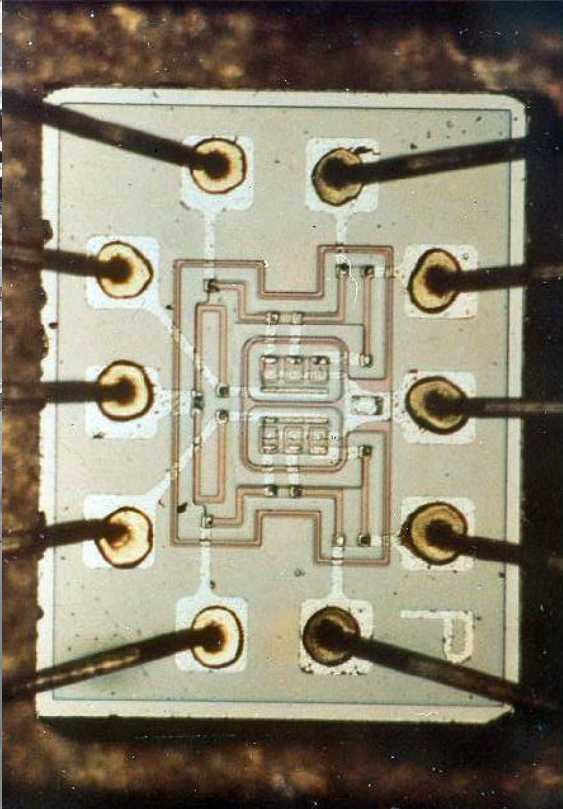

Margaret Hamilton

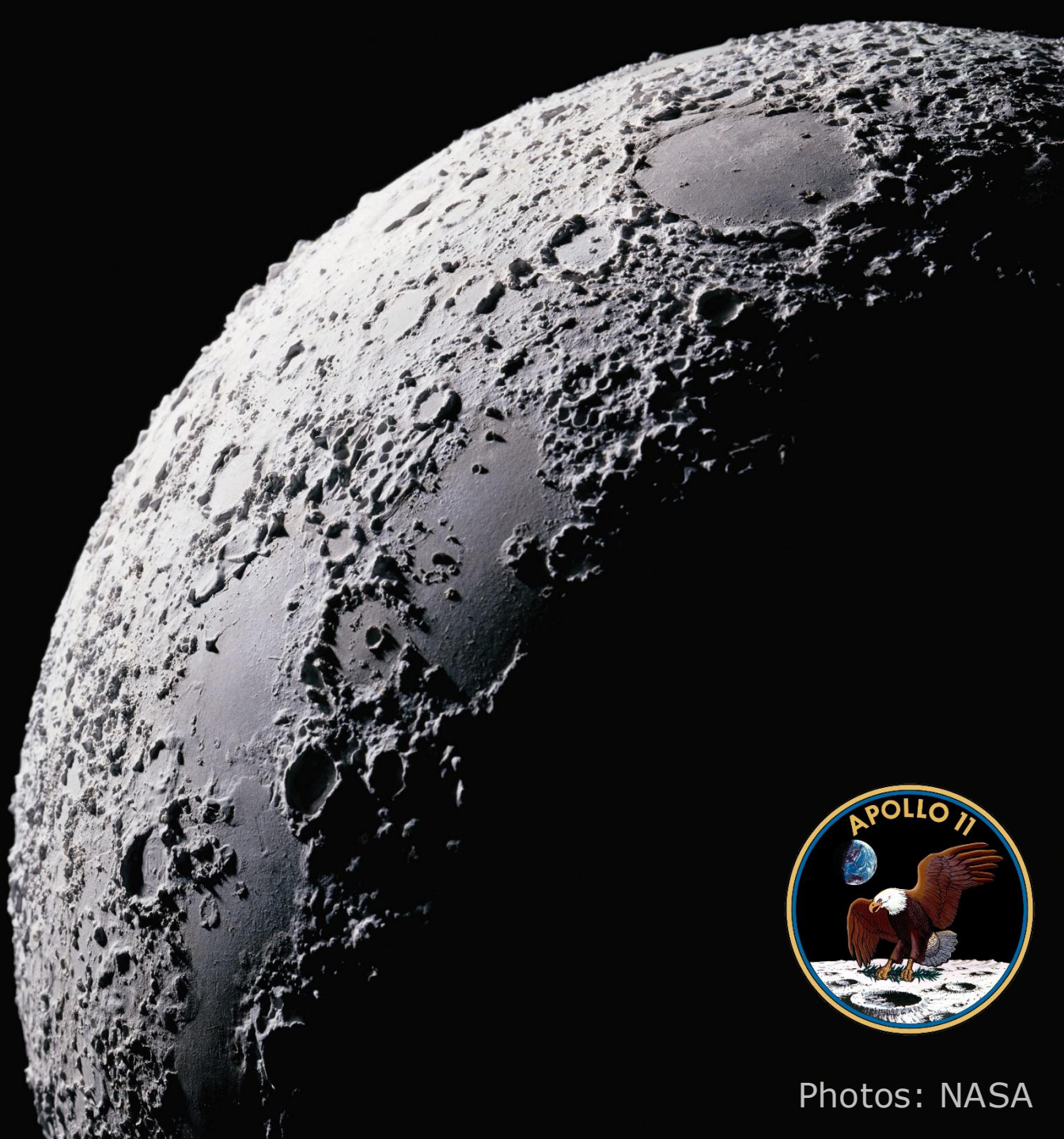
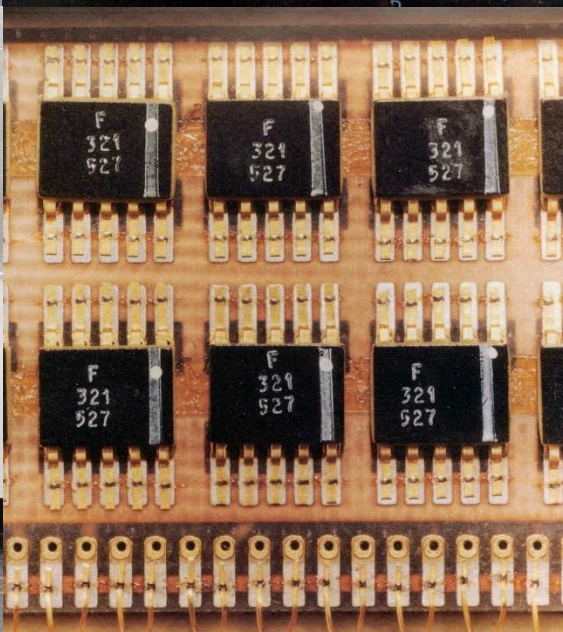

Photos: NASA

1979



**CHALMERS**  
UNIVERSITY OF TECHNOLOGY



1998



# SPARC

1999



European Space Agency

### FREE LEON IS EUROPEAN AGENCY'S SPARC-LIKE CORE

*Includes separate instruction, data caches, 32-bit memory bus*

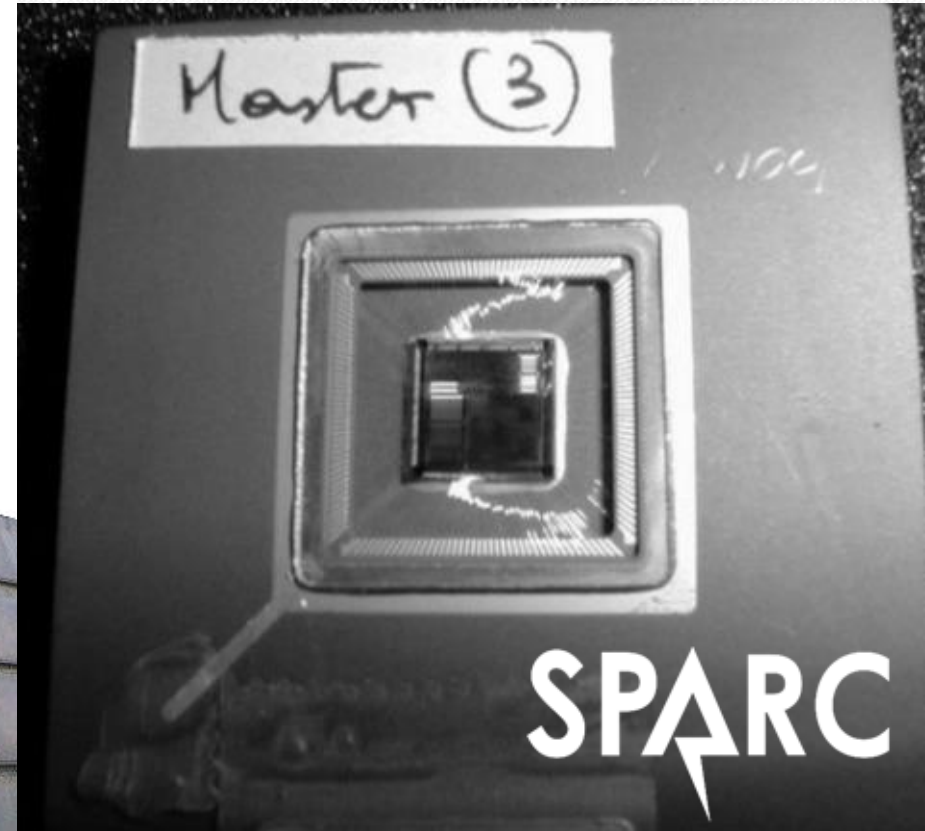
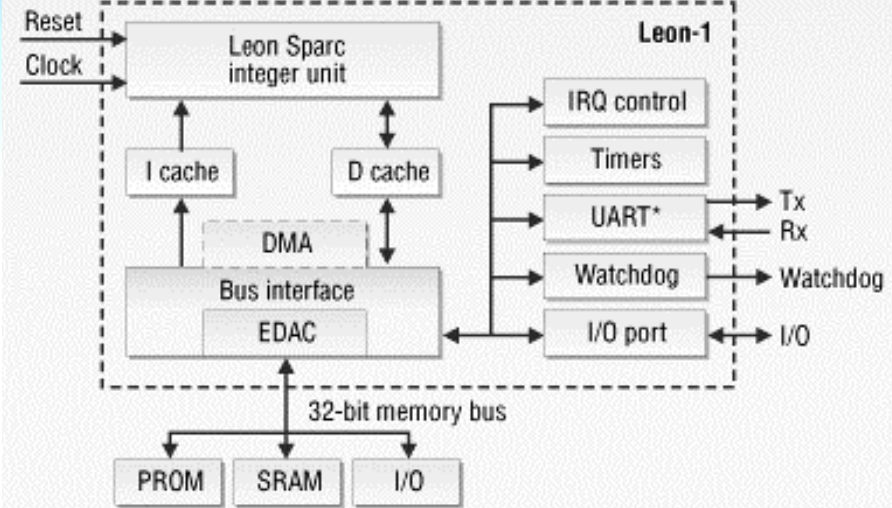

2001

```

std_logic_vector(unsigned(r.ahb_haddr(log2(LINESZMAX*4)-1 downto log2(busw/8))) :=
end if;
v.ahb_htrans := "11";
if (r.ahb_haddr(log2(ilinesize*4)-1 downto log2(busw/8))=
  | onev(log2(ilinesize*4)-1 downto log2(busw/8))) and
  | (r.ahb_hsize(1 downto 0)/="10" or r.ahb_haddr(log2(busw/8)-1 downto 2)=onev(log2(busw/8)-1 downto 2)))then
  v.ahb_htrans := "00";
end if;
elsif r.ahb2_inacc='1' and ahbi.hresp(1)='1' then
  -- Move haddr backward for retry/split
  if r.ahb_hsize(1 downto 0)="10" then
    v.ahb_haddr(log2(LINESZMAX*4)-1 downto 2) :=
    | std_logic_vector(unsigned(r.ahb_haddr(log2(LINESZMAX*4)-1 downto 2))-1);
  else
    v.ahb_haddr(log2(LINESZMAX*4)-1 downto log2(busw/8)) :=
    | std_logic_vector(unsigned(r.ahb_haddr(log2(LINESZMAX*4)-1 downto log2(busw/8)))-1);
  end if;
  v.ahb_htrans := "10";
end if;
end if;
keepreq := '1';
if (v.ahb_haddr(log2(ilinesize*4)-1 downto log2(busw/8))=
  | onev(log2(ilinesize*4)-1 downto log2(busw/8))) and
  | (r.ahb_hsize(1 downto 0)/="10" or v.ahb_haddr(log2(busw/8)-1 downto 2)=onev(log2(busw/8)-1 downto 2)))then
  keepreq := '0';
end if;
-- write read data buffer into I$ data RAM
ocrami.icramin.address(IOFFSET_HIGH-ILINE_LOW downto 0) :=
  r.irdbufaddr(IOFFSET_HIGH downto IOFFSET_LOW) & r.iramaddr;
if r.cctrl.ics(0)='1' and r.irdbufen='1' then
  ocrami.icramin.twrite(0 to ISETS-1) := r.i2hitv;
  ocrami.icramin.tenable(0 to ISETS-1) := r.i2hitv;
  ocrami.icramin.dwrite(0 to ISETS-1) := r.i2hitv;
  ocrami.icramin.denable(0 to ISETS-1) := r.i2hitv;
end if;
if ( ((not ENDIAN) and r.ahb3_rdbvalid(LINESZMAX-1-to_integer(unsigned(r.iramaddr & onev(3))))='1') or
  | ((ENDIAN) and r.ahb3_rdbvalid(to_integer(unsigned(r.iramaddr & onev(3))))='1') ) then
  v.iramaddr := std_logic_vector(unsigned(r.iramaddr+1));
  if r.iramaddr={r.iramaddr'range => '1'} then
    v.irdbufen := '0';
  end if;
end if;

```



MAC 16	3-Port Register File			
MUL 32	7-Stage Integer Pipeline		IEEE 754 Floating-Point Unit	
DIV 32				
I-RAM	Instruction Cache	Data Cache	D-RAM	Debug Interface
Interrupt Control	Memory Management Unit	Power Down	Trace Buffer	
AMBA AHB Interface				

- Minimum Configuration
- Optional Blocks
- Co-Processors





Established 2001 as a spin-off from  
Chalmers and European Space Agency



Located in Gothenburg, Sweden  
80+ employees in Sweden, Germany,  
France, Spain, and United Kingdom



Experts in fault-tolerant computing



Single minded focus on one thing only –  
*radiation hardened microprocessors for space*





2001



Gaisler Research founded

2008



Gaisler Research acquired by Aeroflex  
Aeroflex Gaisler renamed

2014



Aeroflex acquired by Cobham  
Gaisler part of Cobham Advanced Electronic Solutions  
Cobham Gaisler renamed

2020-2021



Cobham acquired by Advent International  
Cobham Advanced Electronic Solutions rebranded as CAES  
Gaisler part of CAES Space Systems division

2023



CAES Space Systems division acquired by Veritas Capital  
CAES Space Systems rebranded as Frontgrade Technologies  
Frontgrade Gaisler renamed

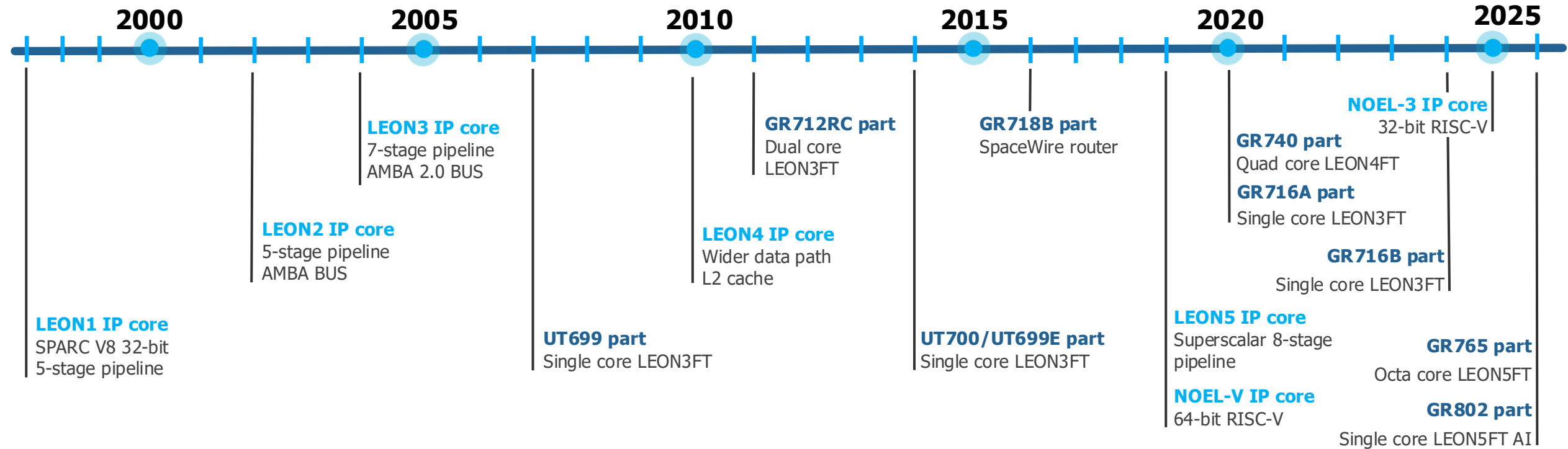

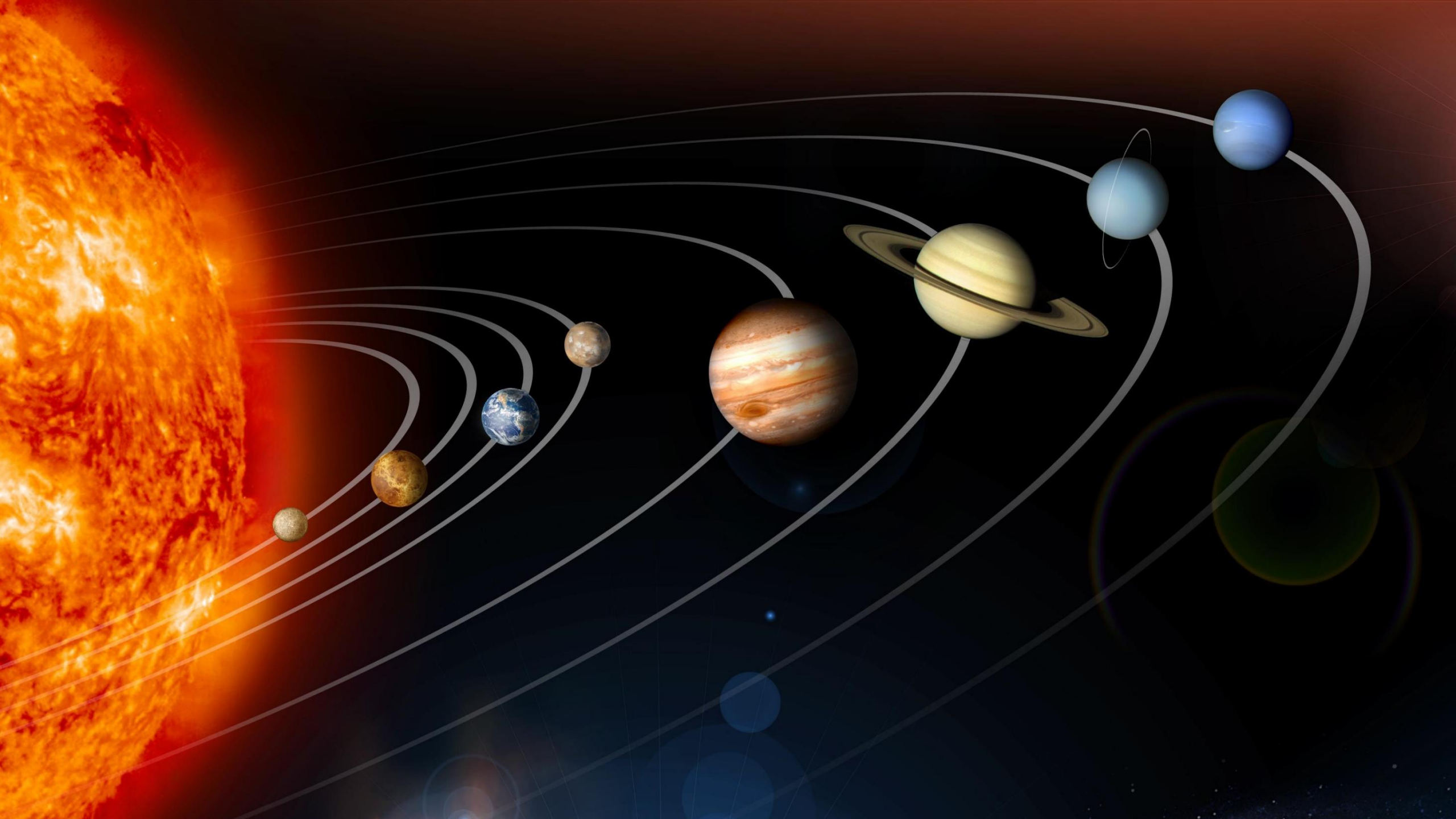

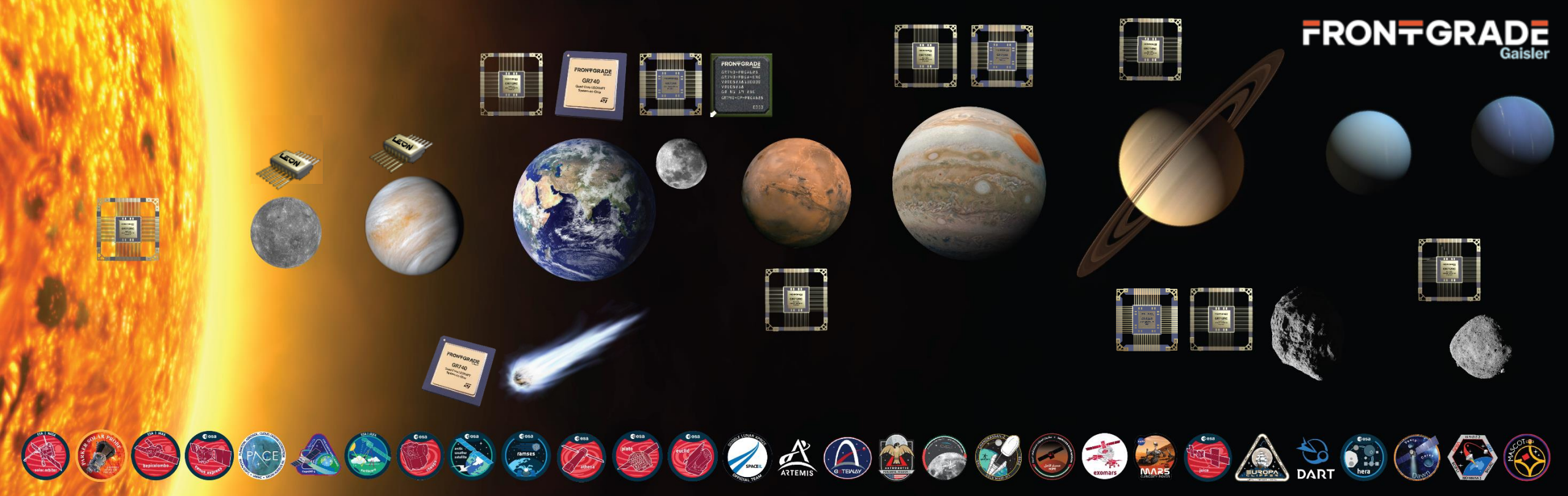

A **world leader** in embedded **computer systems** for harsh environments lies **space** (ranked top three)



Experts in **fault-tolerant** computing and makers of **radiation-hard** component for the space market, with a **unique position** in **Europe** and the **USA**



Providing a full **ecosystem** to support **hardware & software** development in multiple application domains



Implementing **SPARC** and **RISC-V** architectures, catering to **space** and **defense applications**, as well as to **consumer electronics** (e.g. **AI**)



Established 2001 as a **spin-off** from **Chalmers** University of Technology and **European Space Agency**



**American owned subsidiary** located in **Gothenburg**, Sweden, acting as **European non-dependent** company, with **HQ** in **Colorado Springs**, USA.



80+ employees in **Sweden**, **Germany**, **France**, **Spain**, and the **United Kingdom**. Additional 1000+ in the US.



Operating as a **fab-less component suppliers** (manufacturing **outsourced** to foundries, with assembly and test in **Europe**. In-house facilities for advanced hardware and software design, and component laboratory.



Components and technology flying on European missions, including **Galileo**, **Copernicus**, **OneWeb**, **MetoSat**, etc.



Technology used on major launch systems like ESA's **Ariane 6**, JAXA's **H3**, ULA's **Vulcan**, ASI's **Vega**



Technology used in **European defense** for encrypted communications, components on US missions like Space Development Agency's **Tranche 0 Tracking Layer**, **GPS III** ...



Components flown to most celestial bodies in the **Solar System** on ESA, NASA, JAXA, ISRO, TASA etc. probes, with multiple missions to the Sun, Moon, Mars, Jupiter, asteroids, etc.

